

4-WAY TOUCHLESS BUTTON SM-04A

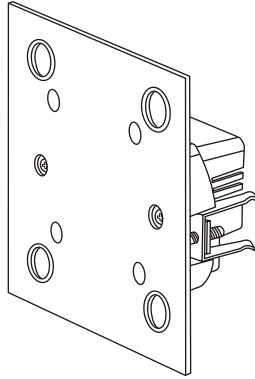

Description

4-Way Touchless button SM-04A is designed to detect objects through most materials. It operates from a low voltage power source and provides four digital outputs when an object is detected in front of a specific section of the button. The sensing area of the button is divided into four quadrants, each acting as an independent button with corresponding digital output. Convenient backlighting indicates the selected button and gives visual feedback to the user.

The sensor works through most materials and can be used as an input device for a wide variety of electronic devices. They use proprietary sensor technology for reliable detection of objects while maintaining a large sensing range.

4-Way Touchless button SM-04A is a convenient way to replace multiple (up to four) push buttons with a single unit. It can be mounted into a standard round European wall box and covered by a variety of switchplates.

The decorative pattern on the switchplate indicates the four distinct sensing areas. Switchplates are attached to the 4-Way Touchless button via four strong rare-earth magnets.

Features

- Innovative alternative to pressure, thermal, infrared, microwave, ultrasonic, and motion sensors.
- Four distinct buttons, each with backlighting indicator and output in a single unit
- Contact closure (Active Low, NPN transistor) outputs
- Reliable way to detect any object (user's hand, foot etc.) through most materials.
- Can be mounted into standard European 68mm diameter round wallbox.
- Countless decorative switchplates available, to match any look or design.
- Switchplates attach via magnets and are easily exchanged or removed for cleaning or sterilisation
- Range adjusted with a potentiometer.
- Low power consumption.
- Excellent noise immunity.

Applications

- Controlling devices requiring pushbutton (digital) control (push-button dimmers, opening doors etc.).
- Home automation systems (using home automation digital (binary) input module).
- Lighting (using power relays or power-packs)
- Motorized window shades and blinds, sunroofs, projection screens
- Touchless combination locks

Specifications

TECHNICAL DATA	SM-04A
Supply input voltage range nom:	12 - 24 V DC
Supply input voltage (min - max):	6 - 30 V DC
Supply current:	15 mA
Output:	4x NPN transistor, Active low, momentary (60V, 100mA max.)
Detection frequency:	2 Hz
Range (single sensor):	Adjustable 2-5cm
Mounting	68mm standard wallbox
Temperature range:	0 °C to +50 °C
Input and output connections:	Screw terminal for wire 2mm (AWG 14) max. for supply power leads RJ45 8-pin connector for output signal wires
Housing dimensions (W x H x D):	90mm x 90mm x 36mm

Dimensions

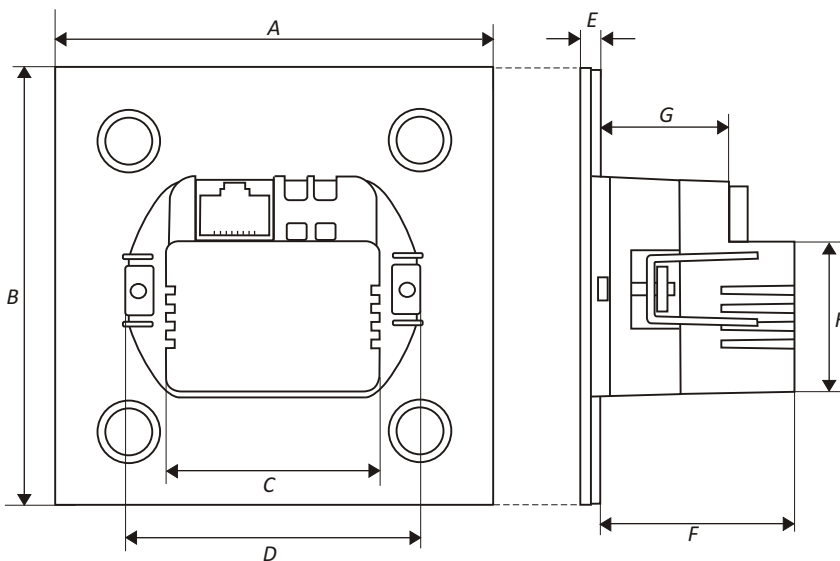

A (width)	90 mm
B (height)	90 mm
C (back housing width)	40 mm
D (top-back housing width)	59 mm
E (sensor thickness)	3 mm
F (depth)	34.4 mm
G (connector level depth)	25.5 mm
H (back housing height)	28.5 mm

Installation

The unit can be mounted into a standard 68mm round European wall box using two holding claws or two screws. If using screws instead of claws, you may have to remove claws to fit the button into a wall box. Please use recessed head-type screws. Check the screw before installation. The screw head should not rise above the sensor surface, otherwise, a decorative switch plate could not be fixed to the button properly. It is recommended that chassis ground is connected to the sensor negative wire. Ground loops should be avoided. Make sure that wire connections are secure, any loose contact in any connection could lead to unstable operation.

Special Anigmo switchplates with decorative markings, indicating four active quadrants of the 4-way button can be mounted on top of the button using magnets.

IMPORTANT: Touchless button and the switchplate in front of it should be securely fixed. Any movement of either the button or the switchplate could force the button into a calibration mode, blocking it for about 30s.

Connection diagram

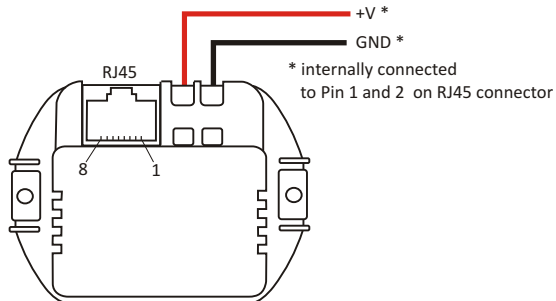

RJ45 connector pinout

1. +V (Power Supply positive)
2. GND (Power Supply Negative)
3. Output 4
4. Output 3
5. Output 2
6. Output 1
7. GND
8. GND

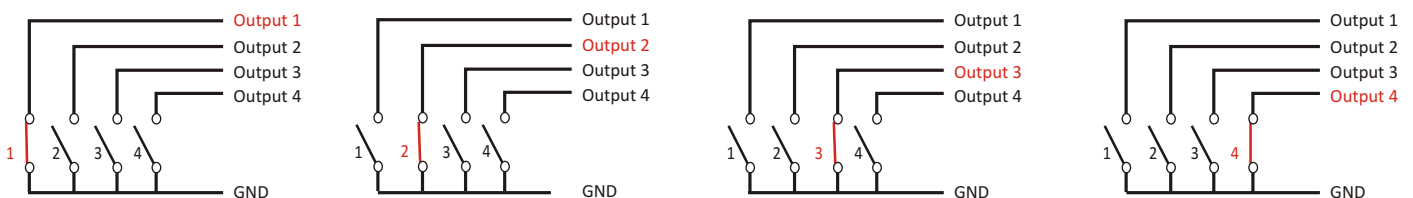
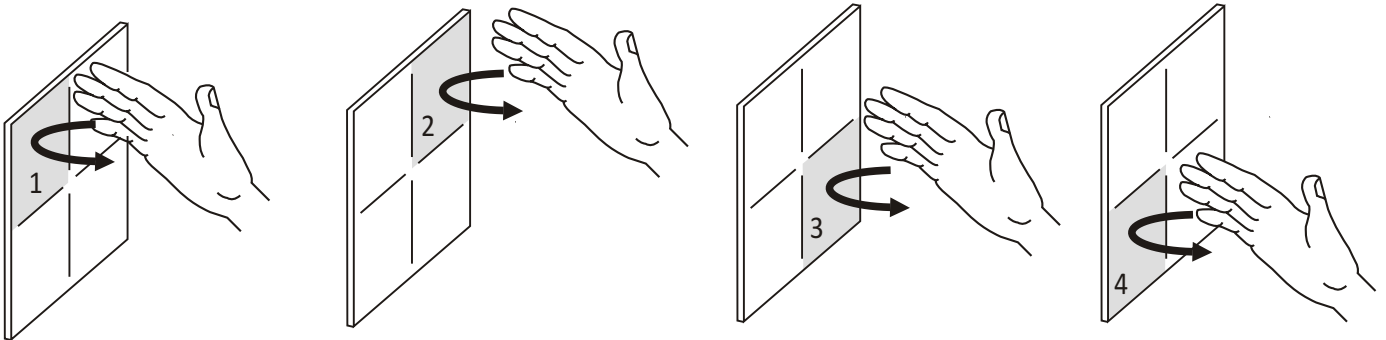

The sensor surface is arranged into four quadrants. Approaching a quadrant with a hand activates the sensor in that quadrant. The corresponding output activates and a background LED indicates that the sensor was activated.

Only one sensor can be active at a time. If two or more sensors are covered, no output will activate.

Output is switched via a OC NPN transistor.

Note 1: The trimmer on the side of the button labeled "RANGE" can be used to adjust sensing range.

Connecting 4-way button to the Home Automation system

The 4-way touchless button can be connected to any Home Automation system that supports binary (digital) inputs. Please check the type of system you are connecting to. Most systems (such as KNX, Z-Wave, Dali ...) have options to connect push buttons, either via special inputs or via binary/digital input modules. Please consult the HA system manufacturer to select the appropriate connection method.

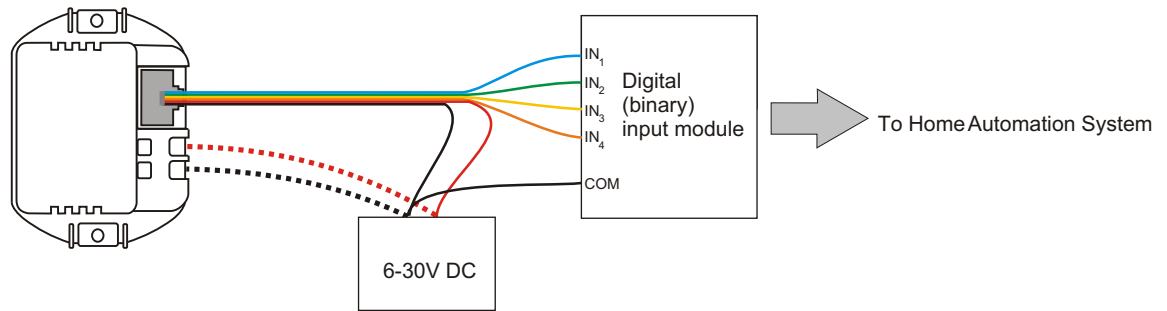

Connecting 4-Way Touchless button to a 4-input Binary Module with separate power supply.
Alternatively, power can be connected to the power connector (dotted lines)

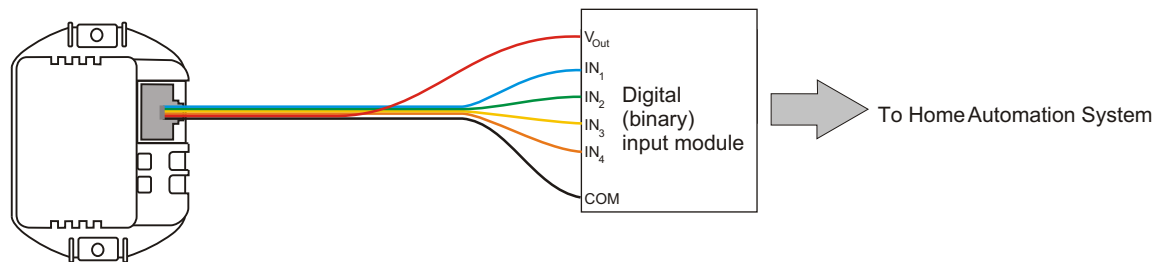

Connecting 4-Way Touchless button to a 4-input Binary Module with integrated power supply output.

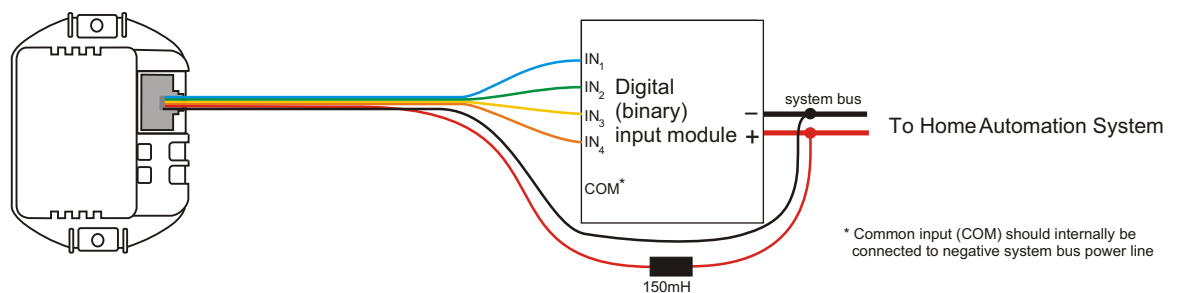

* Common input (COM) should internally be connected to negative system bus power line

Connecting 4-Way Touchless button to a 4-input Binary Module with power derived from the system bus.
Some systems have dedicated power lines, while others share data and power lines (such as KNX). If power lines are shared with data lines, a DC filter must be used (150mH inductor for KNX) between 4-way sensor power input and system bus. Check home automation bus specifications for a specific implementation of the filter.

NOTE: Inputs used on the Home automation system or module should be set to NO (normally open)